



**DURATECH CHIMNEY
5"-8" DIAMETER
INSTALLATION INSTRUCTIONS**



MH7399

A MAJOR CAUSE OF CHIMNEY RELATED FIRES IS FAILURE TO MAINTAIN REQUIRED CLEARANCES (AIR SPACES) TO COMBUSTIBLE MATERIALS. IT IS OF THE UTMOST IMPORTANCE THAT THIS CHIMNEY BE INSTALLED ONLY IN ACCORDANCE WITH THESE INSTRUCTIONS.

Read through all these instructions before beginning your installation. Failure to install the chimney as described in these instructions will void the manufacturer’s warranty and may have an effect on your homeowner insurance and UL listing status. Keep these instructions for future use.

CONTENTS

CLEARANCES.	1
PERMITS.	2
DURATECH CHIMNEY APPLICATIONS.	2
EQUIPMENT & MATERIALS.	2
INSTALLATION NOTES.	3
CHIMNEY DIAMETER.	3
CHIMNEY HEIGHT	3
CHIMNEY PLACEMENT.	4
CHIMNEY ENCLOSURE REQUIREMENTS	4
STOVE RECOMMENDATIONS.	5
STEP-BY-STEP DIRECTIONS	5
CEILING SUPPORTED	5
OFFSET ELBOW INSTALLATION	10
EXTENDED ROOF BRACKET INSTALLATION	11
ROOF SUPPORTED INSTALLATIONS	12
TEE-SUPPORTED INSTALLATIONS	16
MASONRY FIREPLACE INSTALLATIONS	21
ZERO-CLEARANCE FIREPLACE INSTALLATIONS	22
CONNECTION FROM APPLIANCE TO CHIMNEY SYSTEM	22
CHIMNEY MAINTENANCE	23

CLEARANCES

Always allow at least a 2-inch clearance between DuraTech Chimney Pipe and any combustible materials. Never fill any required clearance space with insulation or any other materials. Combustible materials include lumber,

plywood, sheetrock, plaster and lath, furniture, curtains, electrical wiring and building insulation. Keep single wall stovepipe at least 18 inches away from combustible materials, unless a clearance reduction system that is acceptable to the authority having jurisdiction is used, or the appliance to be installed is listed and the instructions specify a different clearance.

PERMITS

Contact your local Building Official or Fire Official regarding permits, restrictions, and installation inspections in your area.

DURATECH CHIMNEY APPLICATIONS

DuraTech Chimney is a complete chimney system tested and listed to UL 103 HT for the United States, and ULC S604 in Canada. In the U.S., DuraTech Chimney can be used with wood stoves, fireplaces, fireboxes, furnaces, boilers, water heaters, stoves, ranges, or other residential-type appliances fueled by oil, gas, coal, or wood, that require a UL103 HT chimney system. In Canada, DuraTech can be used with oil & gas fired appliances listed for use with a Type A Chimney, in accordance with ULC S604 (DuraTech has not been approved for use with solid fuel appliances in Canada). DuraTech Chimney is available in 5", 6", 7" & 8" diameters (UL 103 HT Rated), as well as 10", 12", 14" & 16" diameters (UL 103 Rated). Do not use with forced draft, positive-pressure appliances. The DuraTech Chimney system may have a maximum of two (2) offsets (four elbows total) of 30° from vertical. DuraTech Chimney is listed under UL Re-examination Service Number MH7399.

EQUIPMENT & MATERIALS

Hammer	Drill
Caulking Gun	Plumb Bob
Screwdrivers (Phillips & Standard)	Tin Snips
Saber or Keyhole Saw	Level
Dependable Ladder	Tape Measure
Proper Gloves and Shoes	Eye Protection

Materials You May Need:

500°F RTV Silicone Sealant	8 Penny Nails
#8, 2-1/2" & 1-1/2" Wood Screws	Roofing Nails

INSTALLATION NOTES

Proper planning for your DuraTech Chimney installation will result in greater safety, efficiency, and convenience, as well as saving time and money. You must use only authorized DuraTech Chimney parts to maintain a listed Chimney system (not including the connector pipe). Do not mix parts or try to match with other products, or use improvised solutions. Do not install damaged or modified parts. Table 1 lists the authorized DuraTech Chimney components. Practice good workmanship. Sloppy work could jeopardize your chimney's safety. Keep electrical wiring and insulation away from all chimneys and stovepipes. If you have any questions, be sure to contact either your dealer or Simpson Dura-Vent directly.

Part	Part
6", 12", 18", 24", 36" & 48" Pipe Sections	Firestop Radiation Shield
Elbow with swivel	Attic Insulation Shield
Tee with Tee Cap	Elbow Strap
Adjustable Tee Support Bracket	Adjustable Wall Strap
Chimney Cap	Anchor Plate
Round Ceiling Support Box	Extended Roof Bracket
Trim collars for Round Support Boxes	Adjustable Roof Flashing
Square Ceiling Support Box	Chase Top Flashing
Flat Ceiling Support Box	Flat Roof Flashing
Roof Support	Storm Collar
Trim collar for Roof Support	Transition Anchor Plate
Wall Thimble	Base Tee and Double Base Tee
Finishing Collar	Firestop

CHIMNEY DIAMETER

Follow the appliance manufacturer's instructions to determine chimney diameter and clearances between combustible materials and your heating appliance. Never choose a chimney with an inside diameter smaller than your appliance's outlet. To calculate the chimney's outside diameter, add 2 inches to the inside diameter.

CHIMNEY HEIGHT

The National Fire Protection Association Standard #211 states: "Chimneys shall extend at least three feet above the highest point where it passes through the roof of a building, and at least two feet higher than any portion of a building within ten feet." (Fig 1) DuraTech Chimney may be installed up to 60 feet high. If the chimney extends more than 5 feet above the roof, an Extended Roof Bracket must

be used (see page 12). Due to the overlap of the joints, subtract 1-1/4 inches from each Chimney Section's height to calculate installed height.

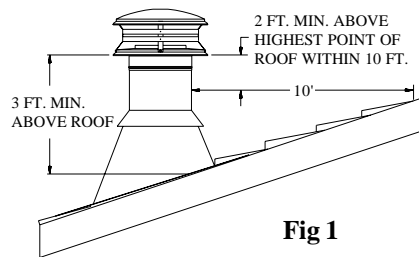

Fig 1

CHIMNEY PLACEMENT

When deciding the location of your chimney, try to avoid modifications to roof beams and other structural components of the building.

CHIMNEY ENCLOSURE REQUIREMENTS

Through Rooms: Interior chimneys shall be enclosed where they extend through closets, storage areas, occupied spaces, or anyplace where the surface of the chimney could be contacted by persons or combustible materials. The space between the outer wall of the chimney and the enclosure shall be at least 2 inches (Fig 2).

Multi-Story: Consult local building codes for requirements in your area. In the U.S., the National Fire Protection Association Standard #211 states: "Factory-built chimneys that pass through floors of buildings requiring the protection of vertical openings shall be enclosed with approved walls having a fire resistance rating of not less than one hour when such chimneys are located in a building less than 4 stories in height, and not less than 2 hours when such chimneys are located in a building more than 4 stories in height." In Canada, except in single-family and two-family dwellings, chimneys which extend through another story must have an enclosure with a fire resistance rating equal to or greater than that of the floor or roof assembly through which they pass.

Cold Climates: In cold climates, chimneys mounted on an outside wall should be enclosed in a chase. Exterior chases reduce condensation and creosote formation, and enhance draft. Include an access door by the Tee Cap for chimney cleaning (Refer to Fig 23, page 17).

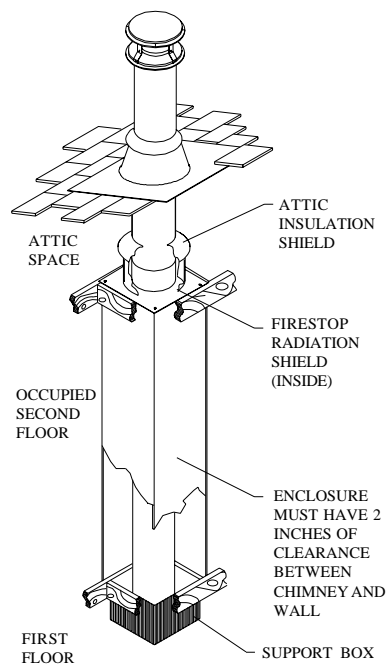

Fig 2

STOVE RECOMMENDATIONS

Follow the stove manufacturer's instructions. The requirements stated below pertain to all stoves or other appliances installed with DuraTech Chimney systems.

Choice: Choose an appliance that is listed by a recognized testing laboratory, is appropriate for your needs, and is not larger than required.

Installation: Once the chimney system is in place, install the stovepipe to connect the appliance to the chimney as described in the appliance manufacturer's instructions. Be sure to maintain all required clearances.

Flues: Connect only one solid fuel appliance per chimney.

Operation: Follow the appliance manufacturer's instructions for maximum efficiency and safety. Overfiring can damage the appliance, stovepipe and chimney.

Fuels: Do not burn driftwood, plastic, or chemically treated wood such as railroad ties. They are corrosive to your appliance, stovepipe and chimney. Follow the appliance manufacturer's instructions and safety manual in regards to fuels. Not all appliances are equipped to burn coal. Coal with a low sulfur content will reduce the possibility of corrosion.

Mobile Homes: Please read the appliance manufacturer's instructions and safety manual carefully. Not all appliances are listed for use in mobile homes.

STEP-BY-STEP DIRECTIONS

There are five general types of DuraTech Chimney installations:

1. Ceiling-supported
2. Roof-supported
3. Tee-supported (through-the-wall)
4. Masonry Fireplace
5. Zero-Clearance Fireplace

Review the step-by-step directions before beginning your installation.

CEILING SUPPORTED

1. Place Appliance: Position the appliance according to the manufacturer's instructions. The flue outlet collar should be placed between the rafters or joists above, if possible.

2. Frame Support Opening: Drop a plumb bob to the center of the appliance's flue outlet and mark this center point on the ceiling. Refer to Table 2 for specific framing and clearance dimensions. Mark appropriate cutting lines around the center point. Cut a square hole in the ceiling for the Support Box. Frame a level, square opening centered over the hole which you have cut. (Figures 3 and 4).

3. Install Support: For installation into a flat ceiling, you may use either the Round Support Box, the Flat Ceiling Support Box, or the Square Ceiling Support Box. The

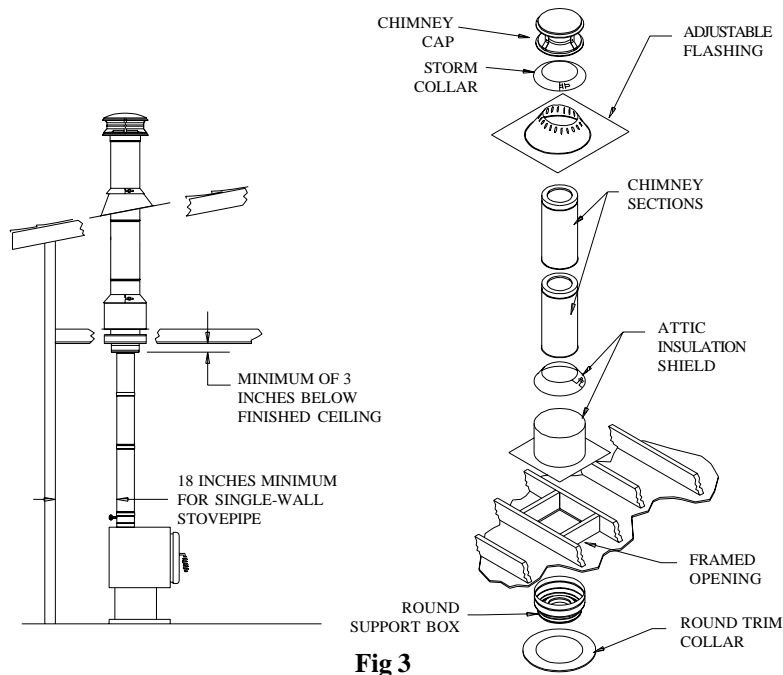

Fig 3

Flat Ceiling Support Box is primarily used for Oil Appliances and comes unpainted. For the Square Ceiling Support Box, refer to the Square ceiling installation below. The Round Ceiling Support Box has the option of a square or round Trim Collar available (Fig 5). The bottom of the Round Support Box must extend at least 3 inches below the finished ceiling. Level the Support Box and secure it to the framing using at least three 8-penny nails per side (min. of 12 total). Alternatively, you may use 1-1/2" #8 wood screws (min. of 12 total), instead of nails. Next, secure the Trim Collar (round or square) to the framing members using the (4) 1" long, round-head wood screws provided (Fig 6).

For installation into a cathedral ceiling, you must use the Square Ceiling Support Box and the two-piece Trim. The bottom of the square portion of the Support Box must be a minimum of 2-inches lower (round portion is an additional 3 inches lower) than the finished ceiling at the lowest side of the penetration (Fig 5 & 6). Level the

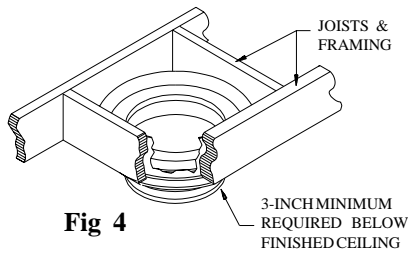

Fig 4

Support Box and secure it to the framing using at least three (3) 8-penny nails per side (minimum of 12 nails total), or a minimum of (3) #8, 1-1/2" wood screws. Adjust the overlapping "U-shaped" Trim pieces so they cover the Support Box, and secure them to the framing members

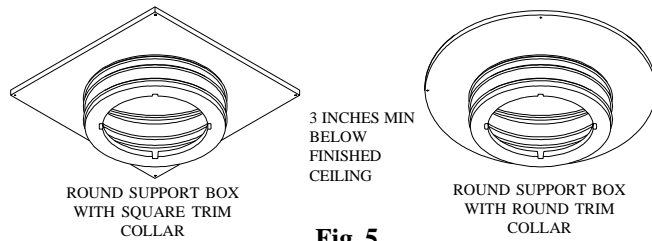

Fig 5

using the (6) 1-1/4" long, round head wood screws provided (see Fig 6).

4. Frame Openings: Frame openings in each ceiling or floor above the Support Box (Fig 7). These openings are to hold the Firestop Radiation Shield and Attic Insulation Shield. Locate each opening by dropping a plumb bob to the four corners of the opening below. Maintain the minimum clearances and dimensions as specified in Table 2. If Elbows must be used to avoid an obstruction, refer to the Offset Elbow Installation section.

5. Cut Roof Opening: Cut an opening in the roof directly above the opening below, and at least 4 inches larger than the chimney's outside diameter to provide at least a 2-inch clearance all around the chimney. The chimney must be centered within this opening and maintain the 2-inch clearance to combustibles.

6. Install Firestop Radiation Shield: A Firestop Radiation Shield is required in multistory installations at each floor penetration above that where the Support Box is located. Example: in a multistory home where the appliance is on the ground floor (Support Box is in the 1st floor ceiling), you would need a Firestop Radiation Shield at the 2nd floor ceiling, and at the 3rd floor ceiling, etc., including where the chimney penetrates into the attic. Figure 7 shows a typical 2-story installation with an attic. Note: a Firestop Radiation Shield is not installed where the chimney penetrates through the roof. The Firestop Radiation Shield is installed on the underside of the ceiling/floor framing, with the cylindrical "tube" portion of the shield

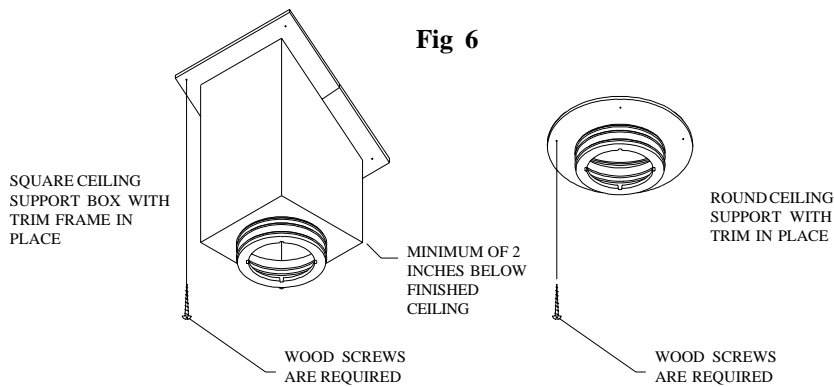

Fig 6

pointing upward (Fig 8). Use a minimum of either (1) 8 penny nail or (1) #8, 1-1/2" wood screws per corner. Refer to Table 2 for framing requirements.

7. Assemble Chimney Sections:

Lower the female end of the first Chimney Section in the Support Box (Fig 9). It will twist-lock clockwise onto the male end of the Support Box. Turn Pipe Sections firmly clockwise to lock them together. Sheet metal screws are not required, but they may be used to reinforce the connection, if desired. Use only 1/2" (or shorter) sheet metal screws. Do not penetrate the inner liner of the chimney.

8. Install Attic Insulation Shield:

Install the Attic Insulation Shield where the chimney passes into an attic. It's purpose is to prevent debris and insulation from getting too close to the chimney (Fig 10). An installed Attic Insulation Shield is 15 inches high. In attic areas where this shield cannot fit, you must enclose the attic portion of the chimney in a framed enclosure. If the chimney is fully enclosed through the attic, an Attic Insulation Shield is not required. If the chimney passes into the attic, install the Attic Insulation Shield as follows:

- a. If the Firestop Radiation Shield extends above the attic floor, no modifications are necessary. The

Table 2

FRAMING DIMENSIONS FOR CATHEDRAL CEILING SUPPORT BOX, FLAT CEILING SUPPORT BOX, ROUND SUPPORT BOX, WALL THIMBLE, AND FIRESTOP RADIATION SHIELD				
CHIMNEY INSIDE DIAMETER	5"	6"	7"	8"
FRAMED OPENING INSIDE DIMENSIONS	11 1/4" x 11 1/4"	12 1/4" x 12 1/4"	13 1/4" x 13 1/4"	14 1/2" x 14 1/2"

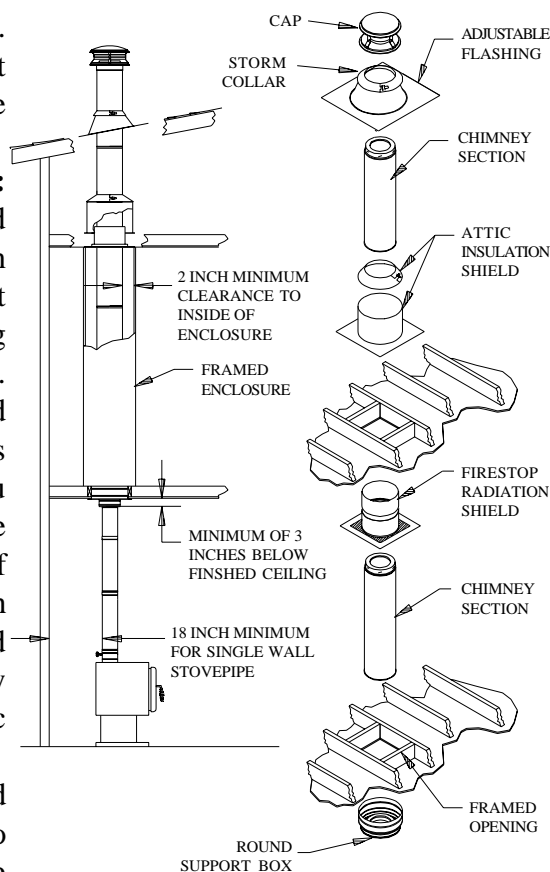

Fig 7

Firestop Radiation Shield will fit inside the Attic Insulation Shield.

b. Assemble Chimney Sections until at least 18 inches of chimney extends above the Firestop Radiation Shield.

c. Extend the Firestop Radiation Shield tube extension (keep at least 1" overlap), and secure in place using sheet metal screws.

d. Slip the Attic Insulation Shield over the Chimney and Firestop Radiation Shield until the base sits squarely on the framed opening (Fig 7 & 10).

e. Secure the Attic Insulation Shield to the top of the framed opening using at least (3) 8-penny nails or (3) #8, 1-1/2" wood screws per side (Fig 10).

f. Wrap the Collar of the Attic Insulation Shield around the chimney and fasten it loosely. Slide the Collar down to meet the Attic Insulation Shield. Slip the tab through the adjacent slot and fold it back to tighten and secure the Collar (Fig 11).

9. Attach Flashing: In new construction, assemble the Chimney Sections to a point above the roof, then slip the Flashing over the chimney. On an existing roof, center and install the Flashing before extending the chimney above the roof. Allow space to permit sliding the next Chimney Section up through the Flashing. Always insure the chimney remains vertical (use level), and that at least a 2-inch clearance to combustible materials is maintained all around. Install the upper edge of the Flashing under the roofing. Nail to the roof along the upper edge and down each side with 1-inch roofing nails. Do not nail the lower edge of the Flashing (Fig 12). Be sure to follow local building practices, as needed. Seal all nail heads with a non-hardening waterproof sealant. On flat or tarred and graveled roofs, nail and seal the Flat Roof Flashing to the roof on all sides with roofing compound. Do not put screws through the Flashing into the Chimney Pipe.

10. Finish Top: Apply a high-temperature (500°F), non-hardening waterproof

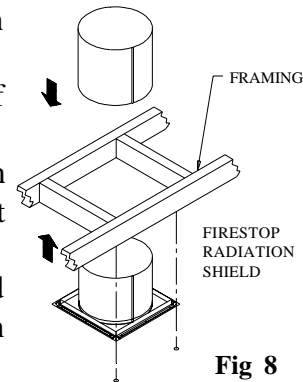

Fig 8

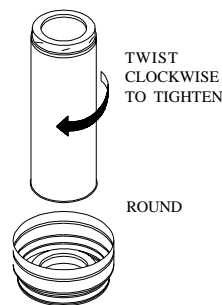

Fig 9

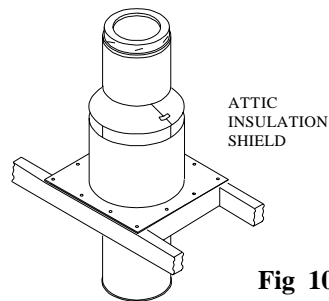

Fig 10

sealant around the chimney at the point where the Storm Collar will meet the chimney just above the Flashing. (Figures 12 and 13). Slide the Storm Collar down over the chimney to the top of the Flashing. Tighten and seal the Storm Collar against the sealant. After installing sufficient Chimney Sections to meet the height requirement (Fig 1), attach the Chimney Cap onto the top of the chimney by holding the collar of the cap and twist locking it clockwise

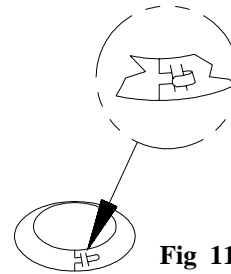

Fig 11

onto the chimney. Do not hold upper portion of the cap and twist, as this may damage the cap. The Chimney Cap can be removed for chimney cleaning as described in the Chimney Maintenance section of the instructions. Use an Extended Roof Bracket if the chimney extends more than 5 feet above the roof. (Figures 16 & 17 in the Extended Roof Bracket section). If you are located in heavy snow country, it is recommended that a "splitter" be installed, and should be fabricated from heavy gauge sheet metal (Fig 14). This will protect the chimney by routing the snow around it. This item is not furnished by Simpson Dura-Vent.

11. Enclosures: Enclose chimneys where they pass through occupied spaces, including closets. Always maintain at least a 2 inch clearance between the chimney and any combustible materials. Interior enclosures may be constructed with standard framing and sheathed with sheetrock or plywood. Use Wall Straps as needed to maintain a minimum of 2 inches of air space between the chimney and combustible materials.

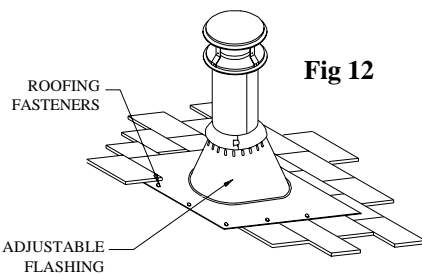

Fig 12

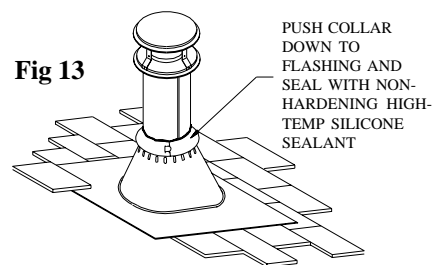

Fig 13

OFFSET ELBOW INSTALLATION

Elbows are manufactured in 15° and 30° angles measured from the vertical. A 30° Elbow is the largest that can be used in an offset. A 30° Elbow may not be combined with a 15° Elbow to make a 45° offset. Avoid Elbows if possible, since a totally vertical chimney is more efficient. When Elbows are necessary to avoid obstructions such as rafters, ridgepoles, or joists, use no more than 2 pairs of Elbows in any one chimney system.

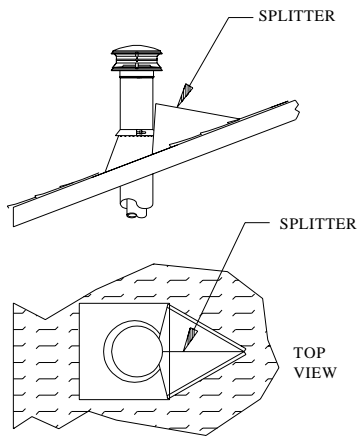

Fig 14

1. Attach Elbows: Attach Elbow to Chimney Section or other Elbow by twisting clockwise until they lock firmly. Attach one Elbow to the Chimney Section below, and align it for the offset. Elbows for DuraTech have a swivel feature that allow for 360° rotation for ease of installation. Refer to Table 3 to determine the required offset length and attach an appropriate length (or lengths) of Chimney Section above the Elbow. The maximum length of chimney pipe between elbows is not to exceed 72" (maximum of two chimney sections only). Attach the second Elbow above the Chimney Section to complete the offset (Fig 15).

2. Secure Offset: Place the Elbow Strap's band around the angled portion of the top Elbow, then tighten the nut and bolt until the clamp is firm. Wrap the Elbow Strap end over an adjacent joist or rafter and secure it with at least (2) 8-penny nails or (2) #8, 1-1/2 screws. Do not add more Chimney Sections until the Elbows are supported. Be sure that the chimney remains vertical. If there is more than one Chimney Section between the Elbows, install a second Elbow Strap around the joint of the two Chimney Sections (Fig 15).

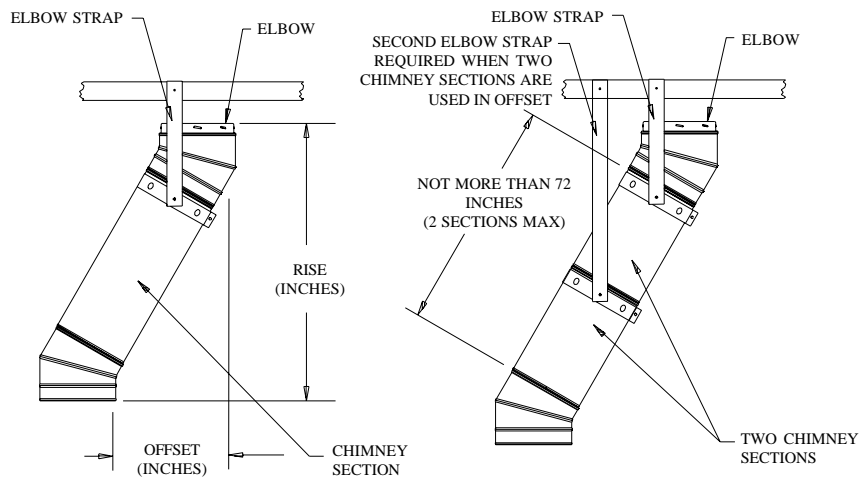

Fig 15

EXTENDED ROOF BRACKET INSTALLATION

If the chimney extends more than 5 feet above the roofline, an Extended Roof

Bracket must be installed at every 5-foot increment of chimney height above the roofline, leaving no more than 5 feet of chimney extending above the last pipe bracket. The Extended Roof Bracket consists of the Pipe Band, the Adjustable Legs, and the Roof Brackets.

1. Mount Pipe Band: Slip the Pipe Band around the chimney and secure by tightening the nut and bolt.

2. Attach the Legs: The Adjustable Legs of the assembly will adjust from 67" to 114". Secure one end of the Legs to the Pipe Band using the nuts and bolts included (1 per Leg). Position the Adjustable legs so they form approximately a 60° angle with the chimney, and with each other (Figures 16 and 17). Be sure that there is at least 3" of overlap between the top and bottom halves of the Adjustable Leg. In order to secure Legs in proper position, there is a hole provided in the outer leg where the outer and inner halves overlap. Use a 1/4" drill bit to drill through the inner leg at that location. Use the nut & bolt provided to pin the Adjustable Legs in position.

3. Install Roof Brackets: Mount the two Roof Brackets where each of the Adjustable Legs meets the roof, using (6) 1" roofing nails per bracket. Seal the nail heads carefully with a non-hardening, waterproof sealant. Attach the bottom end of the Adjustable Legs to the Roof Brackets using the nuts & bolts provided.

TABLE 3
ELBOW OFFSET CHART

Elbow Angle From Vertical	Chimney Length Between Elbows	Offset inches	Rise inches
15°	0"	2	16½
15°	6"	3¼	21¼
15°	12"	4¾	27
15°	18"	6¼	32¾
15°	24"	8	38½
15°	36"	11	50¼
15°	48"	14¼	61¾
15°	48"+6"	15½	66½
15°	48"+12"	17	72¼
15°	48"+18"	18½	78
15°	48"+24"	20	83¾
30°	0"	4	15¾
30°	6"	6¼	20
30°	12"	9¼	25¼
30°	18"	12¼	30¼
30°	24"	15¼	35½
30°	36"	21¼	46
30°	48"	27¼	56¼
30°	48"+6"	29¾	60½
30°	48"+12"	32¾	65¾
30°	48"+18"	35¾	71
30°	48"+24"	38¾	76

ROOF SUPPORTED INSTALLATIONS

There are two types of Roof Supported Installations: (1) Using a Square Ceiling Support Box, and (2) Using a Roof Support.

(1) For a Square Ceiling Support Box installation, make sure that the square box portion of the Support Box can extend at least 2" below the low side of the finished ceiling (Fig 19). The Support Box must remain level, and the top edge of the box must cover the edge of the roof's decking material. Square Ceiling Support Boxes are available in 11-inch, 24-inch, and 36-inch heights. Mobile home chimney

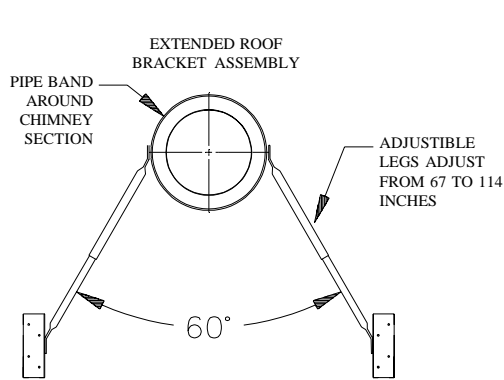

Fig 16

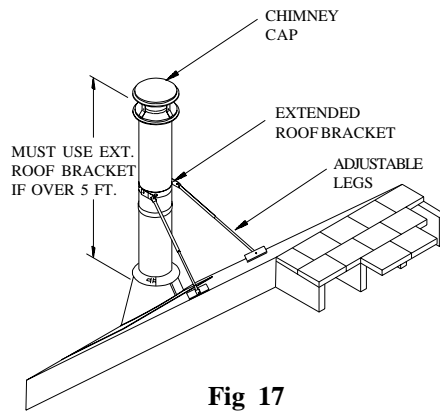

Fig 17

installations are roof supported. Do not seal openings in flashing.

1. Place Appliance: Place the appliance in its proper location, referring to the manufacturer's instructions as to allowable distances from combustibles, etc.

2. Cut Openings: Cut a roof opening in your desired location, just as in a Ceiling-Supported Installation (Steps 1 through 5, page 5). If a separate ceiling and roof exists, as shown in Figure 18 (Low Attic), first cut and frame a ceiling opening as described in Ceiling-Supported Installations (Step 2). Refer to Table 2 for clearance and framing specifications. If it is desired to install through a cathedral ceiling (Fig 19), then the hole is cut in the roof.

3. Install Support Box: Slip the Square Support Box into the framed opening so the square portion projects at least 2 inches below the finished ceiling and rafters (bottom of round portion is 5" below), and extends above the ceiling to framing or decking materials that it can be nailed to. Level the Support Box, and slit the corners to the roofline where they extend beyond it. Bend the flaps (created by the slitting) flush with the roof, and nail the Support Box to the roof or framing with at least three (3) 8-penny nails, or (3) 1-1/2", #8 screws, per side (Fig 20). Be sure to keep the Support Box level. Screw the trim sections into the ceiling (Fig 6).

4. Complete Installation: Refer to Steps 7, 9 & 10 in the Ceiling Supported Installation section to complete the Roof Supported installation.

(2) A Roof Support is also used in installations where there is a cathedral ceiling, and a Square Ceiling Support is not desired. The Roof Support allows the DuraTech chimney to come down into the room below the level of the ceiling (Fig 21). The Roof Support can support a maximum of 45 feet of DuraTech Chimney total, and maximum of 20 feet below the support. If a taller stack of DuraTech Chimney is required, you must use a Square Ceiling Support Box instead.

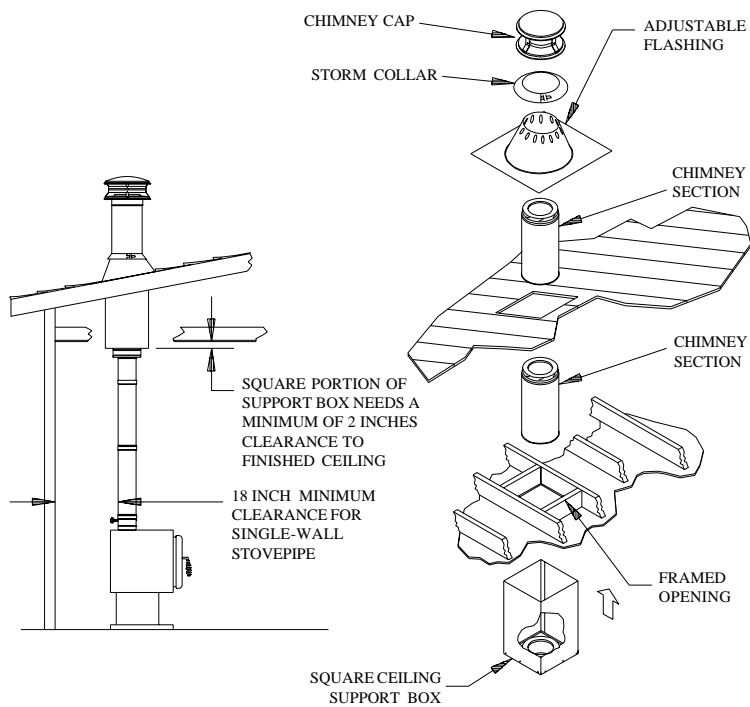

Fig 18

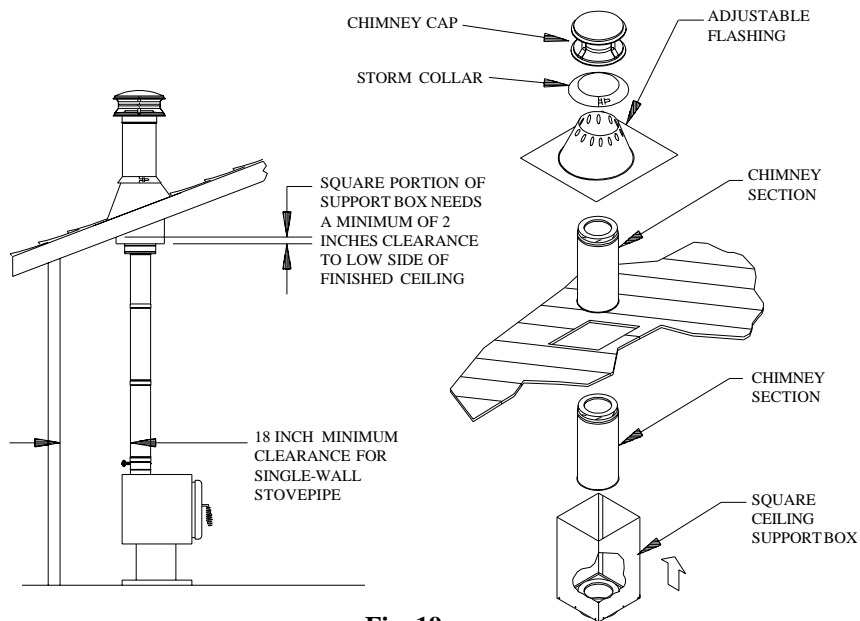

Fig 19

1. Cut and frame opening to provide a minimum 2" clearance on all sides of the chimney pipe. Note: Opening in finished ceiling should be circular/oval in order for it to be covered by Trim Collar.

2. Bolt on the Roof Support Brackets to the Roof Support Band using the supplied hardware. Attach the Roof Support Brackets to roof using (4) 8 penny nails or (4) #8, 1-1/2" screws per side (Fig 21).

3. Determine how much DuraTech Chimney will be extending into the room (minimum of 3" below the ceiling). Be sure to maintain the proper clearance to combustibles (walls and ceilings) for the connector pipe. Once you have identified the proper height for your installation, attach the of the Roof Support Band to the Chimney Section by tightening the Bolt, and secure it by using (4) supplied sheet metal screws.

4. Attach desired length of Chimney Sections above and below the roof level (max. of 45' total, 20' below the support). To transition to the Connector Pipe, attach the Finishing Collar by twist locking it to the bottom section of DuraTech Chimney.

5. Slide Trim Collar over the DuraTech Chimney and attach the Trim Collar to the ceiling using (4) 1-1/4" screws provided (Fig 21).

6. Refer to Steps 10 & 11 in the Ceiling Supported Installation section (page 9) to complete the Roof Supported installation.

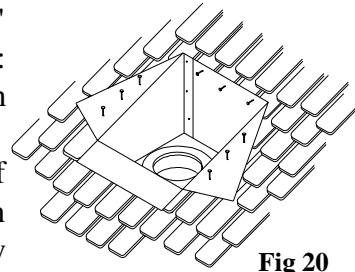

Fig 20

Alternative Installation Location for Roof Support: The Roof Support may be used at the bottom of a Chimney installation (Fig 22). This may be useful for some

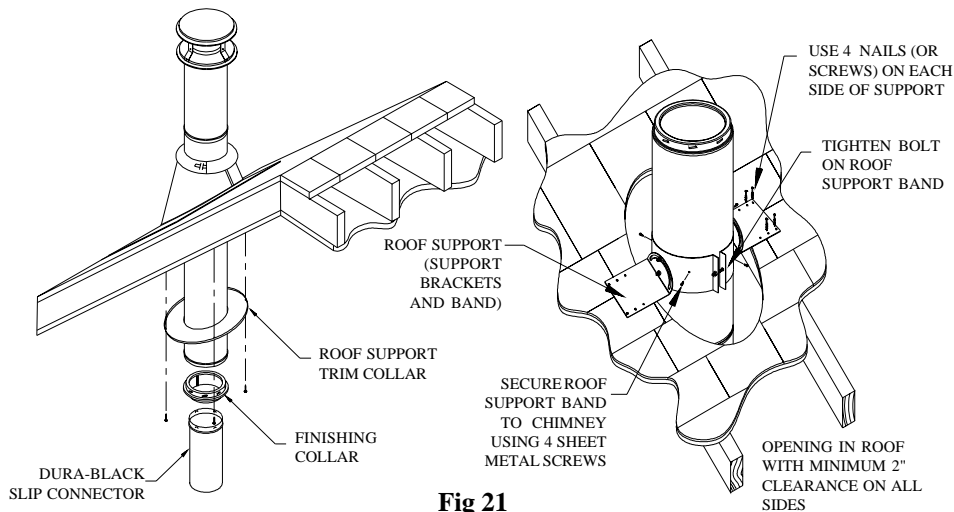

Fig 21

basement installations. Maintain a minimum of 2" clearance to combustibles at all times. The DuraTech Chimney needs to extend a minimum of 3" below the finished ceiling or exposed framing members. Please note that you cannot extend the chimney all the way to the appliance - you must have some connector pipe.

1. Cut and frame opening to provide a minimum of 2" clearance on all sides of the chimney. Be sure to maintain the proper clearance to combustibles for the connector pipe.

2. Bolt on the Roof Support Brackets to the Roof Support Band using the supplied hardware. Attach the Roof Support Brackets to floor using (4) 8 penny nails or (4) #8, 1-1/2" screws per side (Fig 22).

3. Determine how much DuraTech Chimney will be extending into the room (minimum of 3" below the framing), and attach the of the Roof Support Band to the Chimney Section by tightening the Bolt, and secure it by using (4) supplied sheet metal screws (Fig 21 & 22).

4. Install the specialized Firestop below the finished ceiling or framing members. The Firestop can **only** be used when installed with the Roof Support in this type of installation. Use a standard Firestop Radiation Shield at all other locations.

5. Follow steps 4, 5 & 6 for the Roof Support Installation (page 15).

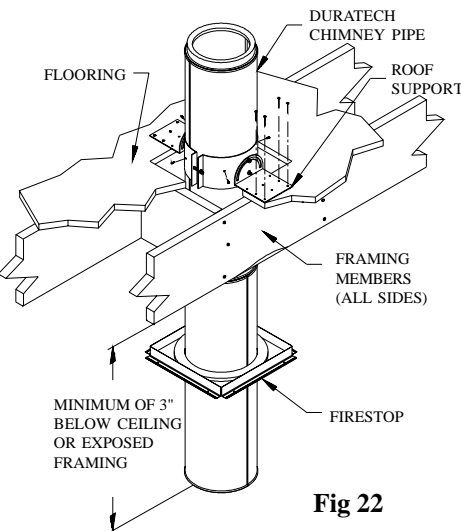

Fig 22

TEE-SUPPORTED INSTALLATIONS

Tee-Supported installations are used when passing through a wall to an outside chimney. The Tee Support can hold a maximum of 60 feet of DuraTech Chimney. The Tee Support and Wall Straps are adjustable, allowing from 2" - 6" of clearance between the chimney and the wall, as needed to fit your installation. There are two options when installing a Tee-Supported installation: the Tee Support above the Tee, or the Tee Support below the Tee. The required parts and general configuration are as shown in Figures 23, 24, 25 and 26.

1. Place Appliance: Position the appliance according to the manufacturer's instructions. It is a good idea to try to position the appliance so it will allow the chimney to line up centered between studs.

2. Locate, Cut & Frame Opening: Determine the location where the chimney

will pass through the wall. The chimney should pass through the wall, centered between two studs. The height of the penetration can be determined by positioning sections of stove pipe until you have the desired configuration (refer to the appliance manufacturer's installation instructions for restrictions on stove pipe). Cut and frame an opening in the inner and outer walls at this location. Refer to Table 2 (page 8) for the appropriate framing dimensions.

3. Install Wall Thimble: The Wall Thimble is a three piece unit which includes the cover plate, sleeve extension, and the back portion with shield. On the outside wall, install the back portion of the Wall Thimble. Center the back portion of the Wall Thimble (with shield inside wall) in the framed opening of the outside wall. Be sure to seal the flange of the Wall Thimble around the wall by using a non-hardening waterproof sealant. Attach the back portion of the Wall Thimble to the outside wall using at least (4) 8-penny nails or (4) #8, 1-1/2" wood screws. Depending on the thickness of your wall, you will need to adjust the shield extension to insure that you have a continuous shield throughout the wall penetration. You may field-fabricate a longer extension tube if needed. Adjustments can be made by sliding the extension in or out of the back portion of the shield. Verify that the shield extension reaches the

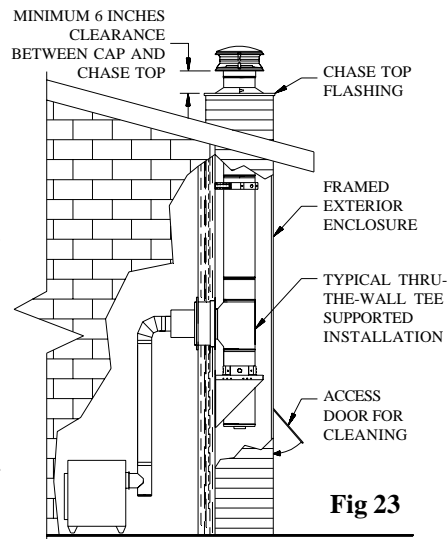

Fig 23

back portion of the Wall Thimble. Center the back portion of the Wall Thimble (with shield inside wall) in the framed opening of the outside wall. Be sure to seal the flange of the Wall Thimble around the wall by using a non-hardening waterproof sealant. Attach the back portion of the Wall Thimble to the outside wall using at least (4) 8-penny nails or (4) #8, 1-1/2" wood screws. Depending on the thickness of your wall, you will need to adjust the shield extension to insure that you have a continuous shield throughout the wall penetration. You may field-fabricate a longer extension tube if needed. Adjustments can be made by sliding the extension in or out of the back portion of the shield. Verify that the shield extension reaches the

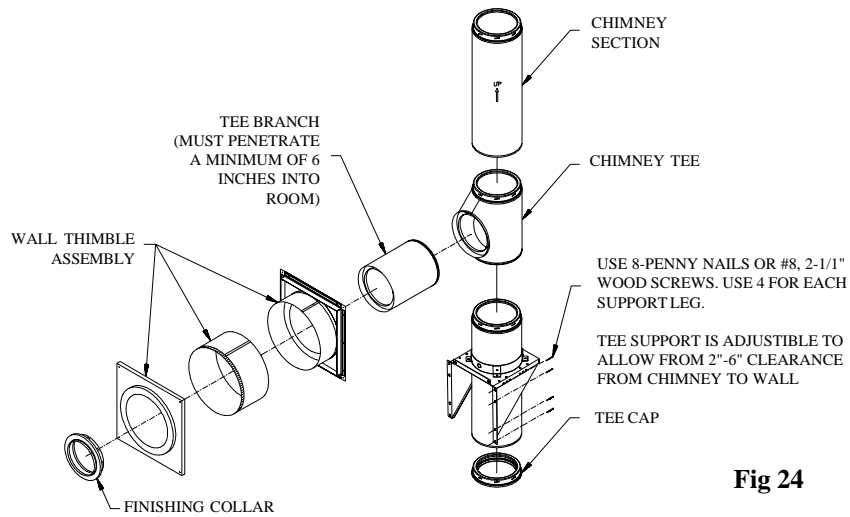
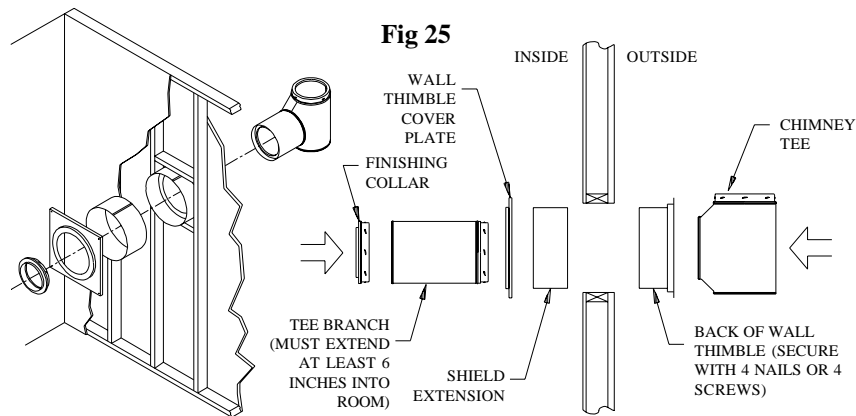

Fig 24



front cover plate when the cover plate is in position. Do not install cover plate at this time. When the shield extension is in position, secure it to the back portion of the shield using (4) sheet metal screws (Fig 25).

4. Install Tee Support: Install the Tee Support on the outside wall. Position Tee Support so that the chimney Tee will be centered inside the Wall Thimble (Figs 24, 25, & 26). The Tee Support may be installed either above the Tee or below the Tee as seen in Figure 26. Important: Verify that Tee Support is level, and secure the leg brackets of the Tee Support to the wall using (4) #8, 2-1/2" screws for each side. Slide support base over leg brackets to adjust for desired clearance to wall, and secure by tightening bolts. (Figs 26 & 27).

5. Install Tee and Cleanout Chimney Section: Twist lock the Tee onto a desired length of Chimney to be used as the cleanout section. Use only one chimney section (any length) to attach to bottom of the Tee. Tighten support band around

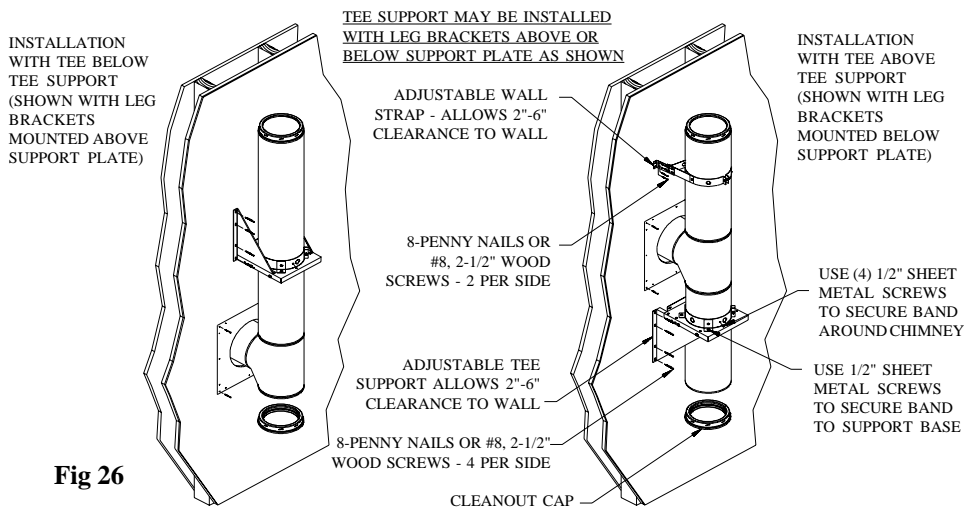

Fig 26

chimney section at proper height to insure that Tee is centered through Wall Thimble (Fig 25 & 26). Use the 1/2" sheet metal screws provided to insure a tight connection between support band and chimney section. Connect support band to support base using the 1/2" sheet metal screws provided (Fig 26). Twist lock Tee Cap into bottom of Chimney Cleanout section.

6. Install Branch onto Tee: From inside the house, attach the Chimney Branch (a 12" or 18" Chimney section, depending on wall thickness, positioned horizontally used to pass through the wall) to the Tee by twist locking it clockwise. Important: The Chimney section used to penetrate through the wall must extend at least 6" into the room (Fig 25 & 27). Use high-temperature sealant (500°F) to seal between the Wall Thimble and the Chimney on the outer wall.

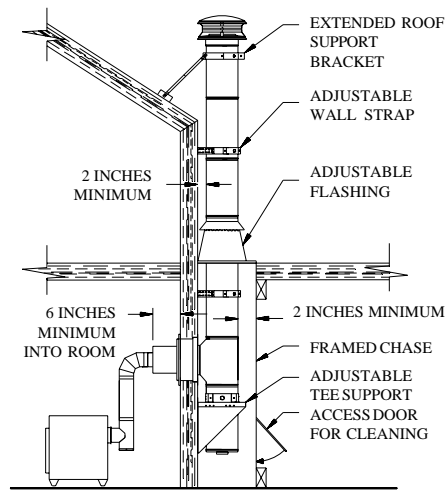

Fig 27

7. Install Cover Plate and Finishing Collar: After the Chimney Branch is secured in place (penetrating at least 6" into the room), slide the Cover Plate over the Branch and attach it to the framing using (4) 1-1/4" long, round head wood screws. Be sure that the Branch is centered in the opening of the Cover Plate. Twist lock the Finishing Collar on to the female end of the Chimney Branch by twisting clockwise.

8. Complete Chimney: Attach the Chimney Sections as in Step 7 in the Ceiling Supported Installation section (page 8). Secure the chimney to the wall with Wall Straps at a minimum of 8-foot intervals and maintain at least 2 inches of clearance to combustible materials. The Wall Straps are adjustable to allow from 2"- 6" clearance to combustibles. Slip the Wall Straps around the chimney, tighten the bolts, adjust the clearance, and fasten the Wall Straps to the wall with (4) #8, 1-

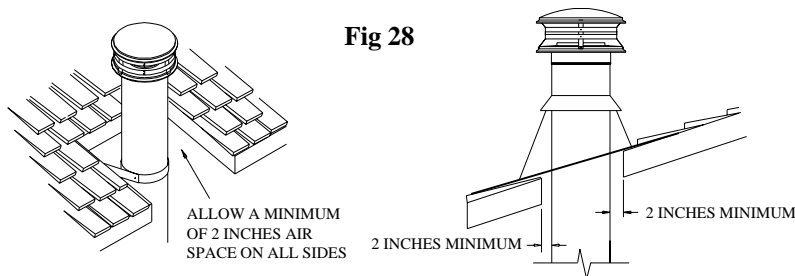

Fig 28

1/2" long wood screws. Once the chimney is at the minimum height specified in Figure 1, attach the Chimney Cap onto the top of the chimney by holding it by the collar and twist locking it clockwise onto the Chimney Pipe. If the chimney penetrates an overhang, frame for at least 2 inches of clearance, and install Flashing and Storm Collar as described in Steps 9 & 10 for Ceiling Supported Installations (page 9). Another option is to cut away the overhang for a 2-inch clearance (Fig 28). If the chimney extends more than 5 feet above the top Wall Strap or Flashing, use an Extended Roof Support Bracket (See page 11).

9. Install Chase Top Flashing: It is recommended that a Tee Supported Chimney be enclosed in a chase. If a chase enclosure has been constructed, you can either use a standard flat-roof flashing, or you can use a Chase Top Flashing. Using a Chase Top Flashing allows for a lower profile for the chimney. The Chase Top Flashing has an opening that is 3" larger in diameter than the DuraTech Chimney. If the Chase Top Flashing can fit over your chase enclosure as required (Fig 29) then install as directed, or trim as needed. However, if the Chase Top Flashing is smaller than your chase enclosure, you will need to provide a galvanized sheet capable of covering your chase and overhanging the sides by 1/2 - 3/4 inch. Attach the Chase Top Flashing to the galvanized sheet using appropriate sheet metal screws and non-hardening waterproof sealant. Use the Chase Top Flashing

Spacers to allow the proper air-gap clearances on the galvanized sheet. The Chase Top Flashing Spacers are available to insure that the

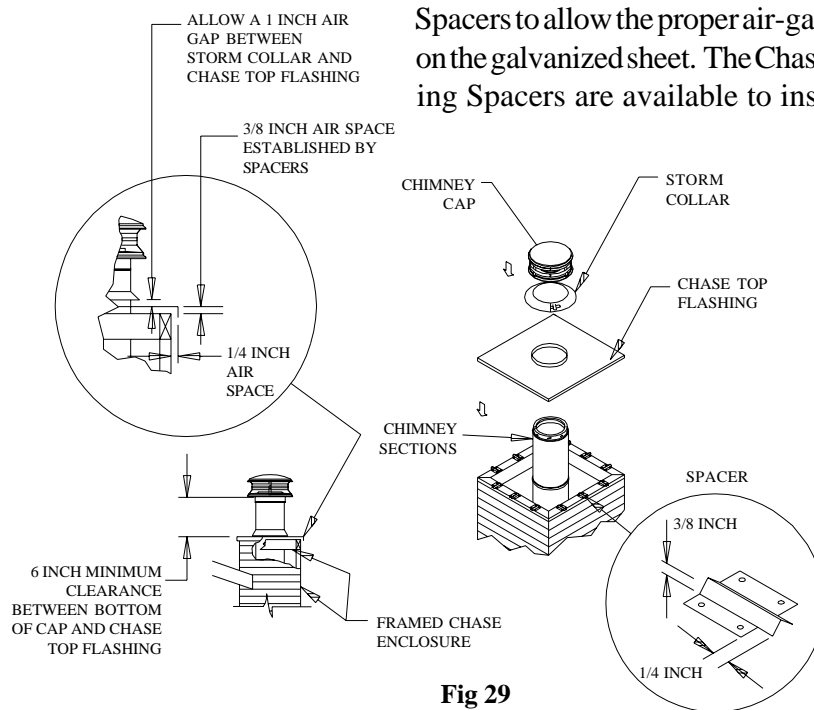

Fig 29

proper air-gap is maintained. Figure 29 displays in some detail, how these air gaps are established using the Spacers and Chase Top Flashing. Secure the Chase Top Flashing to the chase using a sufficient number of #8, 1-1/2" wood screws, being careful to insure the air gap is maintained between the flashing and the chase. Seal the screw heads with non-hardening sealant. When installing the Storm Collar, allow a 1" air space between the bottom of the Storm Collar and the Chase Top Flashing.

MASONRY FIREPLACE INSTALLATIONS

1. Determine Chimney Size: Use Table 4 to determine the correct diameter chimney for your fireplace.

2. Mount Anchor Plate: Chimneys for masonry fireplaces begin with an Anchor Plate. Make sure the surface of the masonry chimney has a level surface on which to attach the Anchor Plate. If the top of the masonry does not have a level surface, then you will need to modify the masonry accordingly. Center the Anchor Plate over the masonry flue opening, and seal the Anchor Plate with a high-temperature (1000°F) sealant. Secure Anchor Plate with (4) 1/4" x 2" masonry anchors (Fig 30). It is very important that the Anchor Plate is level. Be sure to maintain a 1" min. clearance to combustibles from the Anchor Plate.

3. Attach Chimney: Twist lock the first Chimney Section clockwise onto the Anchor Plate.

Table 4

EXAMPLE SHOWS FIREPLACE OPENING AS 36 INCHES WIDE, 30 INCHES HIGH, AND THE CHIMNEY HEIGHT AS 20 FEET. THE CORRECT FLUE SIZE FOR THE SAMPLE PROBLEM IS 12 INCH DIAMETER CHIMNEY.

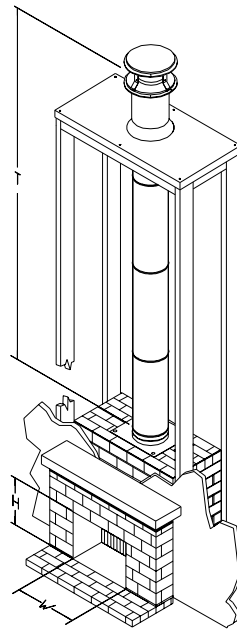
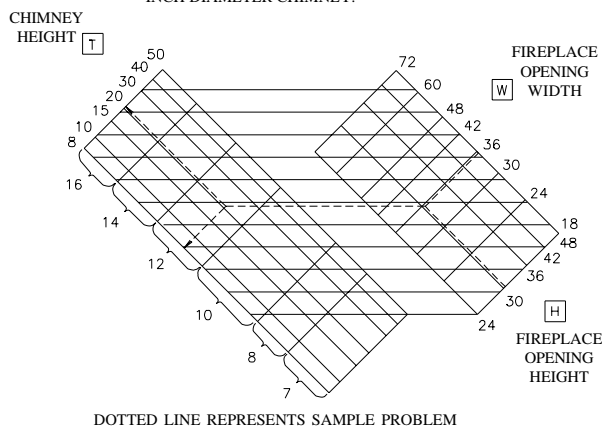

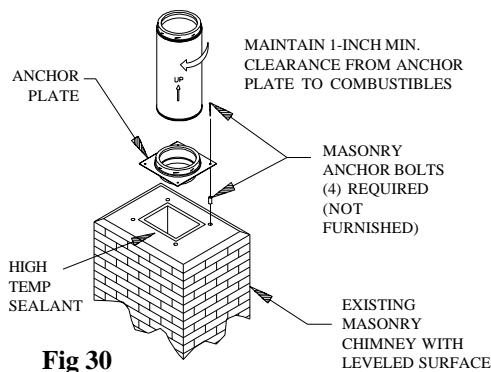

Fig 30

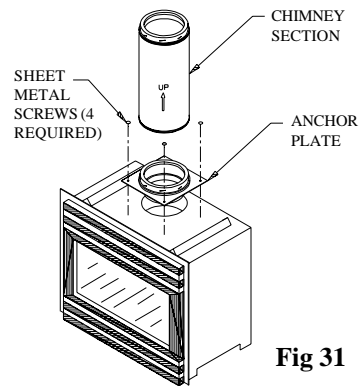

Fig 31

4. Finish Chimney: Install the rest of the chimney as directed in the Ceiling Supported Installation section, Steps 4 through 10 (page 7). Refer to Figure 1 and Table 4 for chimney height requirements. Always maintain at least 2 inches of clearance to combustible materials, and enclose the chimney where it passes through occupied areas. Use a Wall Strap for every eight (8) feet of chimney height.

ZERO-CLEARANCE FIREPLACE INSTALLATIONS

1. Manufacturer's Instructions: Carefully read and comply with the manufacturer's installation instructions for your fireplace. Be sure that DuraTech is approved for use with your appliance.

2. Anchor Plate: Attach an Anchor Plate to the fireplace top with (4) 5/8" sheet metal screws (Fig 31). Check with the appliance manufacture about the use of high temperature sealants.

3. Chimney Sections: Attach a Chimney Section to the Anchor Plate by twist-locking clockwise.

4. Completion: Install the remainder of the chimney as instructed for a standard Ceiling-Supported installation, (using a Firestop Radiation Shield in the 1st floor ceiling instead of the Support Box). Always maintain at least 2 inches of clearance to combustibles, and enclose the chimney where it passes through occupied areas.

CONNECTION FROM APPLIANCE TO CHIMNEY SYSTEM

1. Single Wall Stovepipe: If single wall stovepipe is desired, Simpson Dura-Vent's "Dura-Black" single-wall stovepipe is recommended. The connection to the Ceiling Support Box, or Finishing Collar is made with a Dura-Black Slip Connector or a Snap-Lock Adapter. The beaded end of the Slip Connector or

Snap Lock Adapter slips into the opening in the Ceiling Support or Finishing Collar. Align the tabs on the Slip Connector or Snap Lock Adapter with the notches in the face of the Support Box or Finishing Collar, push it in and rotate to lock it in place. Further instructions for assembling Dura-Black Stovepipe are contained in their shipping cartons. Remember, the minimum clearance to combustibles for single wall stovepipe is 18 inches.

2. Close Clearance Connector Pipe (DVL): Simpson Dura-Vent manufactures a close clearance connector pipe, also referred to as “DVL”. DVL may be positioned as close as 6 inches to a combustible wall, and as close as 8 inches to a combustible ceiling, provided the appliance installation instructions permit this distance. In order to join this type of connector to the Support Box or Finishing Collar, a DVL Adapter is required. The DVL Adapter slips into the opening in the Support Box or Finishing Collar. Align the tabs on the DVL Adapter with the slots cut into the face of the Support Box or Finishing Collar, and push it in, and rotate to lock it in place. Detailed instructions for assembling the remainder of the close clearance system are included in the DVL shipping cartons.

3. Connection to Oil-Burning Appliance: DVL is especially recommended for oil appliances because of the corrosive nature of oil-burning exhaust. When connecting to an oil burning appliance, refer to National Fire Protection Association Standard #211. Table 6-5.1.1 in NFPA 211 states that you must allow for 18" clearance to combustibles if you are using single wall vent connector. If, however, your appliance is Type-L Vent listed and you are using a listed Type-L Vent connector, then you are permitted to use the clearances as specified by the vent listing.

CHIMNEY MAINTENANCE

1. Creosote and Soot: When wood is burned slowly, it produces tar and other organic vapors, which combine with expelled moisture to produce creosote. The creosote vapors condense in the relatively cool chimney flue of a slow-burning fire. As a result, creosote residue accumulates on the flue lining. When ignited, this creosote makes an extremely hot fire.

2. Access: Chimneys must be installed so that access is provided for inspection and cleaning.

3. When to Clean: The chimney should be inspected at least once every month during the heating season to determine if creosote or soot has built up. Check spark arrestor screens at least every 2 to 4 weeks. If creosote or soot has accumulated, it should be cleaned or replaced to reduce the risk of chimney fire.

4. How to Clean: Have your chimney cleaned by a professional chimney sweep if you have doubts about your ability to clean it. Use a plastic, wood, or steel brush. Do not use a brush that will scratch the stainless steel liner of your chimney. Scrub the spark arrestor with a wire brush. To remove the Chimney Cap for cleaning, either twist counter-clockwise to remove the entire cap, or unscrew the four (4) screws that attach the cap's support legs to the cap base. The Tee Cleanout Cap can be removed by turning counter-clockwise. Be sure to replace Tee Cleanout Cap when you are finished cleaning the chimney.

5. Coal: To reduce corrosion in chimneys where coal is burned, clean the chimney thoroughly within 48 hours of shutting down the stove for the season.

6. Chemical Cleaners: Use chemical cleaners only as a last resort, and use only those which the manufacturer specifically warrants as being noncorrosive to the chimney liner. Simpson Dura-Vent will assume no liability for damage resulting from the use of chemical cleaners.

7. In Case of Fire: If a flue fire occurs, close all appliance air inlets, and call your Fire Department. Do not use the chimney again, until it has been inspected for possible damage.

8. Painting: As an option, you can coat all exterior metal parts, with the exception of the Chimney Cap, with high temperature, rust proof paint. Wash the metal with a vinegar and water solution before painting. Painting the chimney will help to increase chimney life.

9. Creosote Formation: Simpson Dura-Vent assumes no liability for any structural damage or roof contamination as the result of creosote formation. It is the owner's responsibility to comply with inspection and cleaning requirements as described in these instructions, and those of the appliance manufacturer.

10. Warranty: Simpson Dura-Vent proudly offers a limited lifetime warranty on DuraTech Chimney components. The warranty includes all components except chimney caps, which are warranted for 5 years. For specific details, refer to the printed warranty included in the Chimney Product Catalog. Dura-Vent, DuraTech Chimney, DVL, Close Clearance Connector, and Dura-Black are the registered trademarks of Simpson Dura-Vent Co., Inc.



SIMPSON DURA-VENT, INC

PO Box 1510
Vacaville, CA
95696-1510

Vicksburg, MS

(800)-835-4429

(707)-446-4740 (FAX)

Visit us on the Web at

www.duravent.com

Feb 2002

L150