

# A MAJOR ADVANCE IN STRUCTURAL FIREPROOFING

- Interior Walls
- Structural Steel Columns



## SUPER FIRETEMP® PASSIVE FIRE PROTECTION AND HIGH-TEMPERATURE INSULATION

### Super Firetemp®

Super Firetemp is a non-combustible, Asbestos Free fireproofing board used in assemblies requiring one to four hour fire ratings, and is capable of withstanding temperatures in excess of 2000°F (1093°C). **Accessories:** Super Calstik® is a high-temperature adhesive designed to bond porous insulating materials. Super Calstik is used to finish all Super Firetemp joints and seams.

### THE ADVANTAGES

- Assured Fire Resistance. Specified fire ratings are achieved by testing in accordance to ASTM, UL, and ULC test standards. Fire-rated assemblies are UL and OPL listed. The desired fire rating determines product thickness.
- Durable. Super Firetemp is hard, solid, and an abrasive-resistant material with excellent physical properties. The material will neither chip nor flake.
- Clean. Super Firetemp is nailed or screwed in place, not blown on. No protective curtains are required.
- Easy to Install. Super Firetemp is easily handled and requires no special tools. The product cuts with a circular saw or a saber saw and is field installed using a power screwdriver and drywall screws or hammer and nails with an automatic nailer.
- Attractive. The product's sanded surface readily accepts paints, wall coverings and veneers.
- All-Weather. Contact Industrial Insulation Group for proper weather protection for outdoor use.
- Economical. Super Firetemp simplifies on-site labor and can greatly reduce overall job costs. Product preparation and application are easy; no special tools are required, and clean up is minimal.
- Uniformly thick with fire rating consistent over every square inch of covered surface.
- Contains no asbestos.
- Zero clearance to combustibles

### APPLICATIONS

Recommended for use on columns, beams, vessels, skirts, saddles, tanks, walls, refractory backups, and other applications that require fire ratings or high-temperature insulations.

### AVAILABLE FORMS AND SIZES

Composed of hydrous calcium silicate, the product features a high-temperature crystal structure with low water of hydration, resulting in exceptional strength and stability under fire conditions in excess of 2000°F (1093°C). White in color, Super Firetemp is available in 4' x 8' (1.22 m x 2.44 m) panels of various densities and finish-sanded up to 3" (76 mm) thick.

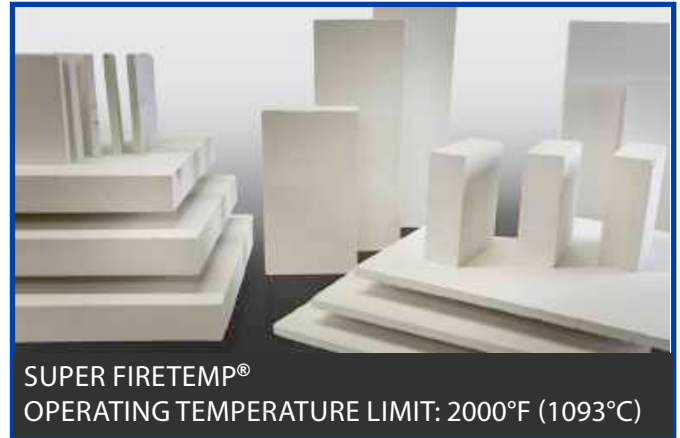

### THERMAL CONDUCTIVITY

Mean Temp	Firetemp L		Firetemp M		
	°F	°C	Btu-in/ (hr-ft²·°F)	(W/m·°K)	Btu-in/ (hr-ft²·°F)
200	93	.54	0.078	.61	0.088
400	204	.61	0.088	.66	0.095
600	316	.67	0.097	.73	0.195
800	427	.73	0.105	.80	0.115

\* Typical average values derived in accordance with accepted test methods subject to normal manufacturing and experimental tolerances. \*\* Other thicknesses available on request.

### PHYSICAL PROPERTIES

PROPERTY	SUPER FIRETEMP L	SUPER FIRETEMP M
Board Size, ± 1/8" (± 3 mm)	4' x 8' (1.22 m x 2.44 m)	4' x 8' (1.22 m x 2.44 m)
Thickness, in. (mm)	¾, 1, 1½, 2, 2½, 3** (19, 25, 38, 51, 64, 76)	½, ¾, 1, 1½, 2, 2½, 3** (13, 19, 25, 38, 51, 64, 76)
Density, pcf (kg/m³)	20 (288)	28 (449)
Compressive Strength @10% Deformation, psi (kPa)	450 (3,103)	900 (6,206)
Flexural Strength, psi (kPa)	260 (1,793)	550 (3,792)
Screw-Holding Strength, lb. (kg)	36 (16)	70 (32)
Dielectric Strength, volts/in. (volts/mm)		30,000-60,000 (1,181-2,362)
Linear Shrinkage, % 24-Hour Heat Soak @ Maximum Temperature	<2	<2
Maximum Continuous Service Temp °F(°C)	1,800 (982)	1,800 (982)
R-Value per in. (mm), @ 75°F(24°C) Mean Temp	2.0 (0.32)	1.7 (0.30)

# Fire Protection Systems

## INTERIOR WALLS

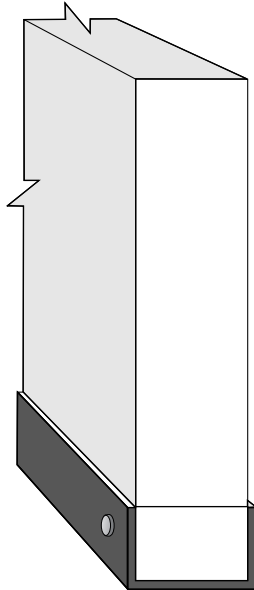

## STRUCTURAL STEEL COLUMNS

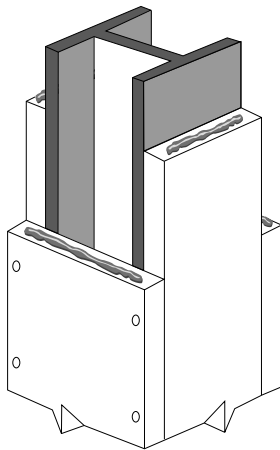

## FIREPROOFING APPLICATIONS

Super Firetemp allows zero clearance to combustibles. Depicted are some of its more common applications. Contact Industrial Insulation Group for complete application data for your specific requirements.

## L-SYSTEM

The Super Firetemp L-System provides maximum fireproofing protection for structural steel beams and columns. Ideal for exterior applications such as a refinery or power plant or interior applications where high traffic requires high durability and good appearance. The L-System consists of Super Firetemp L board clad in .016" (0.4 mm) aluminum or .010" (0.25 mm) stainless steel roll jacketing.

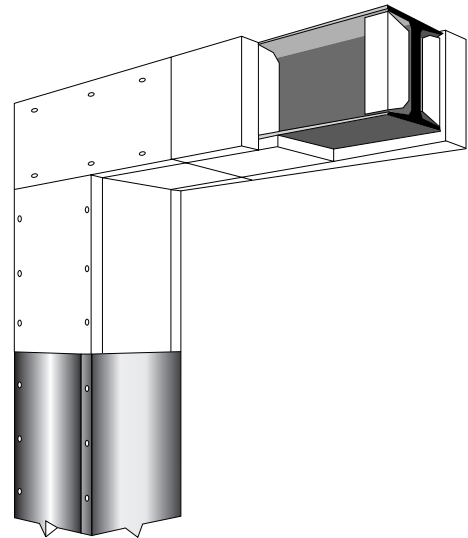

## SUPER FIRETEMP® PASSIVE FIRE PROTECTION AND HIGH-TEMPERATURE INSULATION

### CODE COMPLIANCE

Super Firetemp undergoes stringent tests to comply with some of the toughest fire codes in the US and Canada.



### ISO 9000 CERTIFICATION

Firetemp is manufactured under an ISO 9001:2000 registered quality system. This registration, along with regular independent third-party auditing for compliance, is your assurance that all our products deliver consistently high quality.

### PRODUCT CERTIFICATION

When ordering material to comply with any government specification or any other listed specification, a statement of that fact must appear on the purchase order. Government regulations and other listed specifications require specific lot testing, and prohibit the certification of compliance after shipment has been made. There may be additional charges associated with specification compliance testing. Please refer to IND-CSP-3 for Certification Procedures and Charges. Call customer service for more information.

### ADDITIONAL INFORMATION AND SDS

Please visit our website at [www.jm.com/industrial](http://www.jm.com/industrial)  
**CUSTOMER SERVICE, TECHNICAL & GENERAL INFORMATION**  
**(800) 866-3234**

### SPECIFICATION COMPLIANCE

ASTM E84 Surface Burning Characteristics	Flame Spread - 0 Smoke Developed - 0
ASTM E119 Building Fire Test	1, 2, 3 and 4 Hour Ratings
ASTM E136 Non-Combustible	Passes
ASTM E814	1, 2 and 3 Hour Ratings
ASTM C656	Type II, Grade 5 (Super Firetemp L) Type II, Grade 6 (Super Firetemp M)
ASTM C795/C871/C692 Corrosion: Austenitic Stainless Steel	Passes
Underwriters Laboratories 263 Underwriters Laboratories 1479 Underwriters Laboratories 1709	1, 2, 3 and 4 Hour Ratings 1, 2 and 3 Hour Ratings 1, 2, 3 and 4 Hour Ratings
UBC 2309	2 in. [51 mm]min. thickness of Super Firetemp M
Mine Safety and Health Administration	Approved
National Fire Protection Association 96	Super Firetemp M meets the requirements when installed according to manufacturers installation instructions
National Electrical Code	Protection for Electrical Circuits

### INTERNATIONAL STANDARDS ORGANIZATION

UL Design Numbers U328, U446, U447, X307, XR301	Wall system structural steel
Omega Point Laboratories Design Numbers	GD 515R (Super Firetemp M Only)

Industrial Insulation Group, LLC manufactures MinWool-1200® mineral fiber pipe, block and a variety of other insulations; Thermo-12® Gold Calcium Silicate pipe and block insulation; Microporous Blanket Insulation; Super Firetemp® fireproofing board; SprouleWR-1200® Perlite pipe and block insulation; high-temperature adhesives, and insulating finishing cement. The physical and chemical properties presented herein represent typical, average values obtained in accordance with accepted test methods and are subject to normal manufacturing variations. They are supplied as a technical service and are subject to change without notice. Numerical flame spread and smoke developed ratings are not intended to reflect hazards presented by these or any other materials under actual fire conditions. Check with the Customer Service Office to assure current information. All Industrial Insulation Group products are sold subject to the Johns Manville Limited Warranty and Limitation of Remedy. For a copy of the Johns Manville Limited Warranty and Limitation of Remedy, email [info.industrial@jm.com](mailto:info.industrial@jm.com).

**CUSTOMER SERVICE**  
**TECHNICAL & GENERAL INFORMATION**  
**(800) 866-3234**

